



Arctic Fox LLC—570 South 7th Street—Delano, Minnesota 55328 USA
 Phone: (800) 654-5382 or (763) 972-2758—Fax: (763) 972-2873—www.arctic-fox.com

Arctic Fox Europe—Strijmaden 5—4703 Roosendaal—The Netherlands
 Phone: 31 (0) 165 55 9245—Fax: 31 (0) 165 54 9640—www.arctic-foxeurope.eu

Arctic Fox In-Tank Fuel Warmer with Coolant By-pass Thermostat

Save time and bother—this is the only fuel warmer you install and forget. Run coast to coast, border to border with fuel warming confidence because you are thermostatically protected. Fuel is warmed to the optimum operating temperature in cold weather with the proven Arctic Fox® fuel warmer in-tank design. An all mechanical thermostat integrated into the unit by-passes the fuel warming loop when fuel

FEATURES AND BENEFITS

- By-passes coolant when fuel temperature reaches optimum operating temperature, allowing this fuel warmer to be plumbed in series with other components such as preheaters, air compressors, and cab heater lines, with out affecting coolant flow.
- Integral design fits all fuel tanks, simplifies plumbing and reduces fittings.
- Fully mechanical. No electrical components to cause maintenance problems.
- Maintains temperature levels which are recommended by engine manufacturers for electronic fuel systems, and helps keep the in-tank fuel within the recommended temperature limits for maximum horsepower.
- Works great with engine preheaters to maintain the “coolant loop”.



INSTALLATION HARDWARE REPLACEMENT PARTS

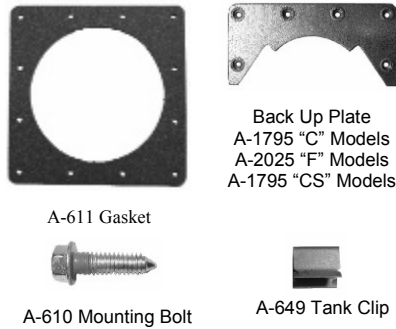

WHERE TO MEASURE TANK

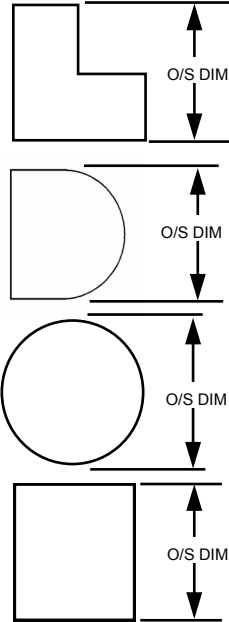

ORDERING INFORMATION: ALL warmers are factory pre-assembled. Order warmers based upon outside tank dimension.
 Example C-406-XX—if tank outside dimension is 27” / 686mm, order C-406-27.

PART NUMBER	TANK DEPTH	COOLANT CONNECTION	FUEL STAND PIPE
C-406-XX	Round 22” thru 29” / 559 thru 737mm	5/8” Hose Barb	NO
C-407-XX	Round 22” thru 29” / 559 thru 737mm	3/4” Hose Barb	NO
C-456-XX	Round 22” thru 29” / 559 thru 737mm	5/8” Hose Barb	YES
C-457-XX	Round 22” thru 29” / 559 thru 737mm	3/4” Hose Barb	YES
CS-406-XX	Round 14” thru 21” / 356 thru 533mm	5/8” Hose Barb	NO
CS-407-XX	Round 14” thru 21” / 356 thru 533mm	3/4” Hose Barb	NO
CS-456-XX	Round 14” thru 21” / 356 thru 533mm	5/8” Hose Barb	YES
CS-457-XX	Round 14” thru 21” / 356 thru 533mm	3/4” Hose Barb	YES
F-406-XX	Flat 14” thru 29” / 356 thru 737mm	5/8” Hose Barb	NO
F-407-XX	Flat 14” thru 29” / 356 thru 737mm	3/4” Hose Barb	NO
F-456-XX	Flat 14” thru 29” / 356 thru 737mm	5/8” Hose Barb	YES
F-457-XX	Flat 14” thru 29” / 356 thru 737mm	3/4” Hose Barb	YES

